

PRODUCT INFORMATION PACKET

Model No: 5KC32GN13
Catalog No: C247
1/4,1800,TEFC,48,1/60/115/230
Fan and Blower Motors



Regal and Marathon are trademarks of Regal Rexnord Corporation or one of its affiliated companies.
©2021 Regal Rexnord Corporation, All Rights Reserved. MC017097E

Nameplate Specifications

Output HP	0.25 Hp	Output KW	0.19 kW
Frequency	60 Hz	Voltage	115/230 V
Current	5.4,2.7 A	Speed	1725 rpm
Service Factor	1	Phase	1
Efficiency	51 %	Power Factor	0
Duty	Continuous	Insulation Class	B
KVA Code	M	Frame	48
Enclosure	Totally Enclosed Fan Cooled	Thermal Protection	N/R
Ambient Temperature	40 °C	Drive End Bearing Size	6203
Opp Drive End Bearing Size	6203	UL	Recognized
CSA	Yes	CE	N
Number of Speeds	1		

Technical Specifications

Electrical Type	Capacitor Start Induction Run	Starting Method	SM
Poles	4	Rotation	Counterclockwise/Clockwise
Mounting	Resilient Base	Motor Orientation	ANY
Drive End Bearing	BALL	Opp Drive End Bearing	Ball
Frame Material	Rolled Steel	Overall Length	9.92 in
Frame Length	5.16 in	Shaft Diameter	0.500 in
Shaft Extension	1.5 in	Thru-bolts Extension	0 in
Outline Drawing	52A102058P1	Connection Drawing	113A326

This is an uncontrolled document once printed or downloaded and is subject to change without notice. Date Created:10/11/2021

SHEET 1
REV 6
SIZE 52A102058

THIRD ANGLE PROJECTION

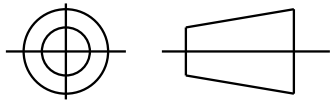

REVISIONS

REV.	DESCRIPTION	DATE	APPROVED
5	REDRAWN BY 2M SOFTWARE CO.	02/12/96	AAU
6	CHG TO RBC FORMAT PER ISO5-1777	12/22/05	DURGA

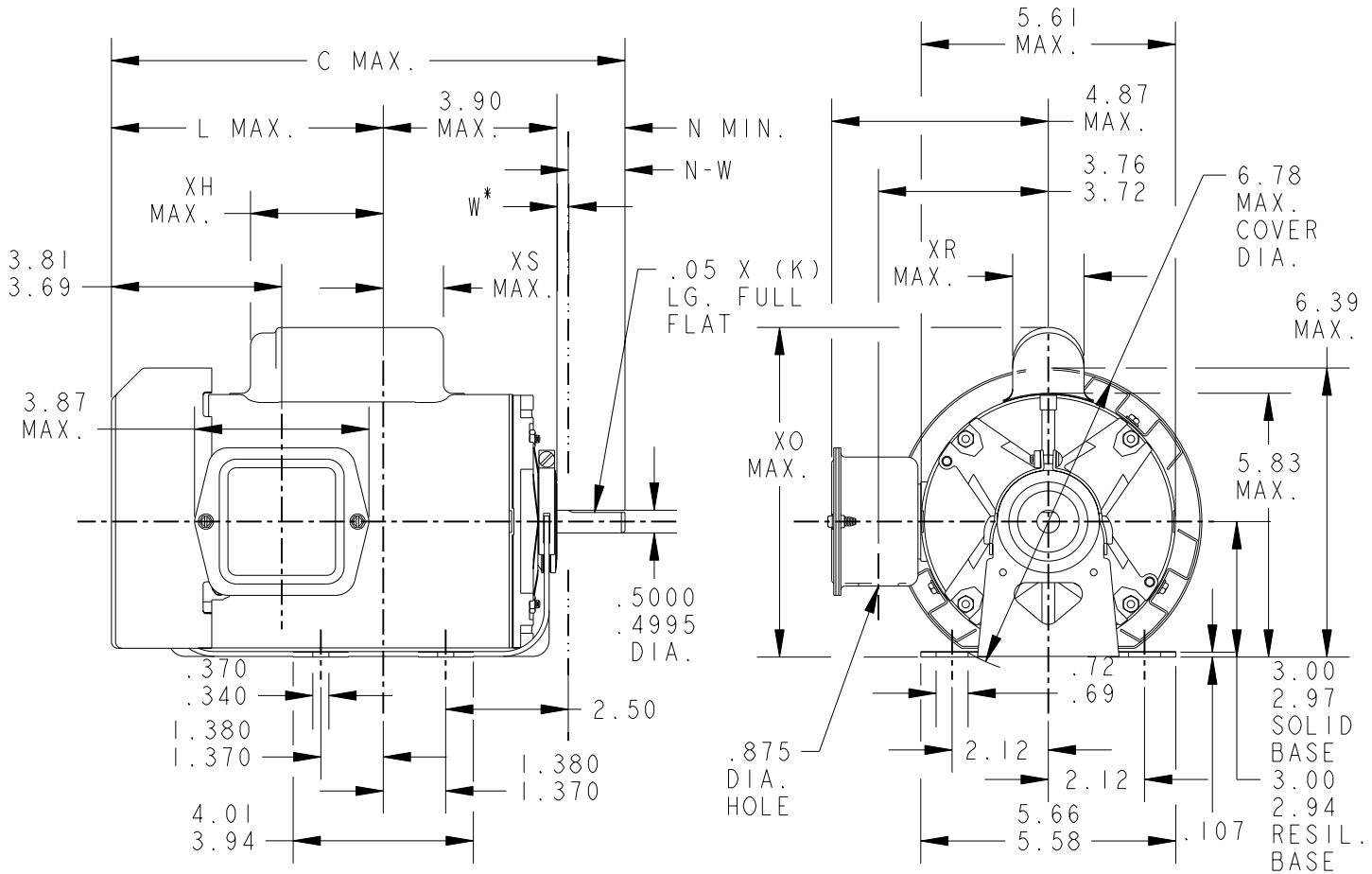

W* IS A CLEARANCE DUE TO VARIATION IN PARTS AND ASSEMBLY

7	KHC	35	48	10.55	1.16	5.17	1.50	1.63/1.41	2.91	7.76	2.08	2.74	
6	KC	38	48	11.98	1.16	6.60	1.50	1.63/1.41	4.02	7.31	1.60	1.75	
5	KC	37	48	11.38	1.16	6.00	1.50	1.63/1.41	3.42	7.31	1.60	2.35	
4	KC	36	48	10.98	1.16	5.60	1.50	1.63/1.41	3.02	7.31	1.60	2.35	
3	KC	35	48	10.55	1.16	5.17	1.50	1.63/1.41	2.59	7.31	1.60	1.97	
2	KC	33	48	10.17	1.16	4.79	1.50	1.63/1.41	2.21	7.31	1.60	2.35	
1	KC	32	48	9.92	1.16	4.54	1.50	1.63/1.41	2.16	7.31	1.60	2.43	
P	TYPE	GE SIZE	NEMA FR	C	K	L	N	N-W	XH	XO	XR	XS	SHELL LGTH

SIGNATURES		DATE		<p>REGAL-BELOIT CORPORATION</p> <p>TITLE OUTLINE GENERAL PURPOSE MOTOR - FORM N - TOTALLY ENCL. OUTBOARD FAN-SOLID OR RESI BASE-BALL OR SLV BRG</p>	
MODEL					
DETAIL		FPK 12/20/76			
CHECKED					
ENGRG					
MFG				<p>SIZE DRAWING A</p> <p>SCALE: 1.000 REF. No.: . SHEET 1 of 1</p>	
FOR ADDITIONAL INFO REFER TO:		QUALITY		<p>52A102058</p> <p>REV 6</p>	
APPLIED PRACTICES		ISSUED			
DIMENSIONS ARE IN INCHES ✓		AAU 02/12/96			
MATERIAL		SOLID MODEL: 52A102058			